

American Standard®

Commercial Gas Water Heaters



MODEL: 100-83-AS

100 GALLON LIGHT DUTY STORAGE

83,000 BTU NAT GAS

83,000 BTU L.P. GAS

The American Standard Commercial Gas Model 100-83-AS is designed to fill the hot water requirements of large residences, small restaurants, businesses, barber and beauty shops, small office buildings and multi-family developments up to seven single or five double bath units.

100-83-AS FEATURES

- Heavy Gauge Steel Tank for extra years of trouble-free service.
- Inner tank glass-lined with Dura-Glas™ and fired at 1600° F for optimum protection from the effects of corrosion.
- R-16.7 non-CFC foam insulated to save energy and reduce fuel costs by maximizing heat retention.
- Two anode rods to prolong tank life.
- Self-Cleaning turbulence inducing cold water inlet-tube engineered to diminish hard water area sediment deposits.
- Full size hand-hole cleanout for eased tank inspection and/or removal of sediment deposits.
- Furnished with four heavy gauge steel legs designed to maximize durability and afford rock-steady installation.
- Automatic non-electric gas thermostat adjustable to 180° F. When installed with a mixing valve, the 100-83-AS can deliver 180° F sanitizing and 140° F general purpose hot water simultaneously.
- Hinged with knob outside access combustion chamber door and sliding inner door to sequester burner and pilot area for added safety.
- Factory installed energy cut-off system and pressure/temperature relief valve.
- Small vent size and top mount 1½" water connections to afford universal replacement of other brands.
- AMERICAN STANDARD gas water heaters are certified at 300 PSI test pressure and for 150 PSI working pressure.
- All tanks are hydrostatically tested at the factory.
- Tested and listed with CSA International in accordance with ANSI Z21.10.3 - CSA 4.3 for up to 180° F operation as an automatic storage and/or automatic circulating tank heater. ASHRAE Standard 90.1 1999 addendum 90.1b and is NSF approved.
- Three year limited warranty on inner glasslined tank and one year limited warranty on all other component parts.

THIS WATER HEATER MEETS THE REQUIREMENTS
OF ASHRAE AND MEETS OR EXCEEDS THE
THERMAL EFFICIENCY REQUIREMENTS
OF CALIFORNIA AND OTHER STATES RECOGNIZING ASHRAE.

100-83-AS SPECIFICATIONS AND APPLICATION DATA

SPECIFICATIONS

MODEL NUMBER	TANK GALLONS CAPACITY	BTU INPUT NAT GAS	REC GPH 100° RISE	BTU INPUT L.P. GAS	REC GPH 100° RISE	THERM EFF %
100-83-AS	100	83,000	81	83,000	81	80%

*For Propane (LP) Gas Model add suffix "LP"; For SCAQMD Low NOx Model add prefix "N"

DIMENSIONS SHOWN IN INCHES

EXTERIOR DIMENSIONS			V E N T	TOP WATER PIPE SIZE	WATER I.P.S. CONNECTIONS		GAS I.P.S. CONN.		H G T T O T O P E N I N G	T&P O P E N I N G
A	B	C			HEIGHT TO TOP CONNECT	TOP WATER SPREAD	H G T	S I Z E		
70 ³ / ₄	28	68 ¹ / ₈	4	1 ¹ / ₂	71 ⁵ / ₈	16	18	1/2	59 ¹ / ₂	3/4

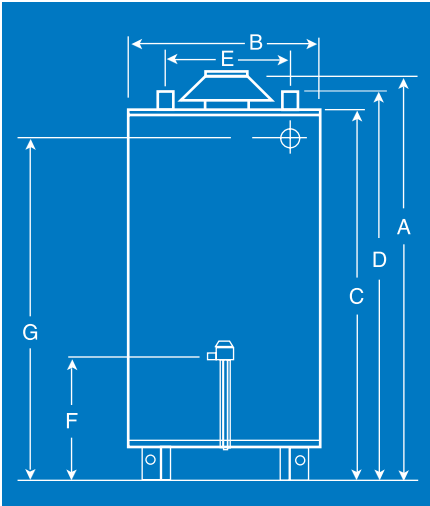

RECOVERY IN GALLONS PER HOUR AT VARIOUS TEMPERATURE RISES

MODEL NUMBER	GAS TYPE	BTU INPUT	TEMPERATURE RISE										
			40°	50°	60°	70°	80°	90°	100°	110°	120°	130°	140°
100-83-AS	NAT	83,000	201	161	134	115	101	89	81	73	67	62	58
	LP	83,000	201	161	134	115	101	89	81	73	67	62	58

MAXIMUM HOT WATER DELIVERABILITY AT VARIOUS TIME PERIODS

STORAGE CAPACITY U.S. GALLONS	ONE HOUR RECOVERY 100° RISE	1 ST HOUR	2 HOURS	3 HOURS	GPM REC. 100° RISE
100	81	151	232	313	1.4

Note: Recovery rate indicated on heater rating plate is based on 75% (76%) thermal efficiency according to CSA (ANSI, Z.21.10.3). Manufacturer reserves the right to make product changes and/or improvements with or without notice.

SAMPLE SPECIFICATION

Commercial gas water heater shall be AMERICAN STANDARD model _____ having a storage capacity of _____ gallons, operate on _____ Gas, with a BTU input of _____ and a recovery rate of _____ gallons per hour at 100° F temperature rise. Water heater tank interior shall be glass lined with Dura-Glas™, furnished with four anode rods and insulation shall be non-CFC foam of R-16.7. Water heater shall be CSA certified.



"Living Up to A Higher Standard"

American Standard® Commercial Water Heaters

2808 Metropolitan Place • Pomona • CA 91767

1 (800) 900-9063 • (909) 392-0230 • Fax (909) 392-7302